

# DOMESTIC TANK

FREE STANDING TANK

330 IMP. GALLONS

TOP VIEW

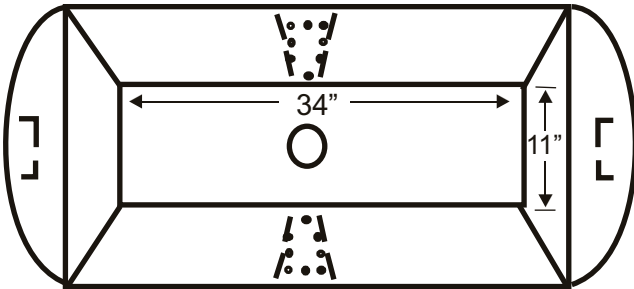

FRONT VIEW

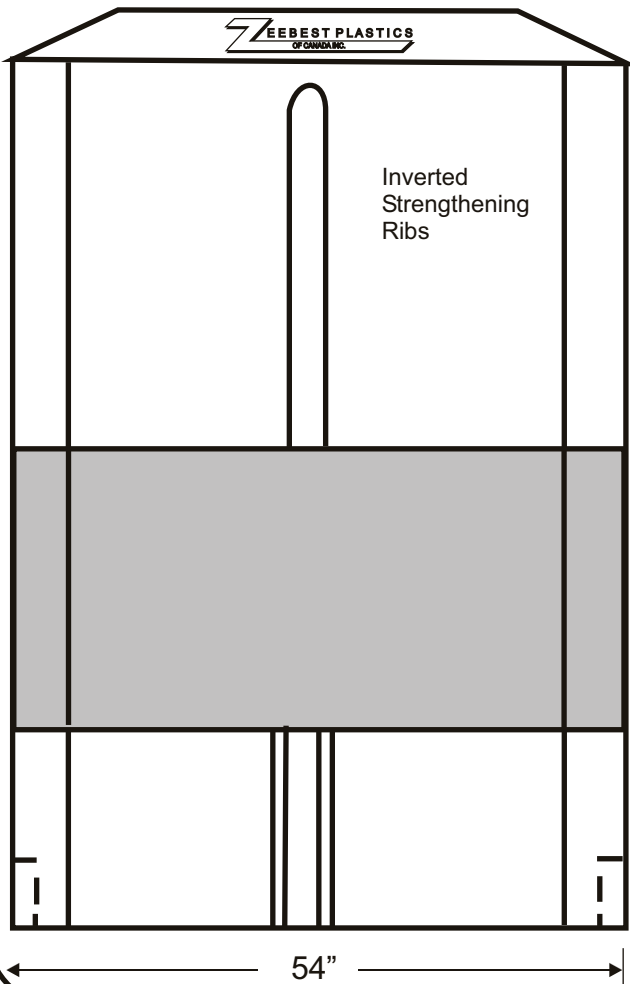

END VIEW

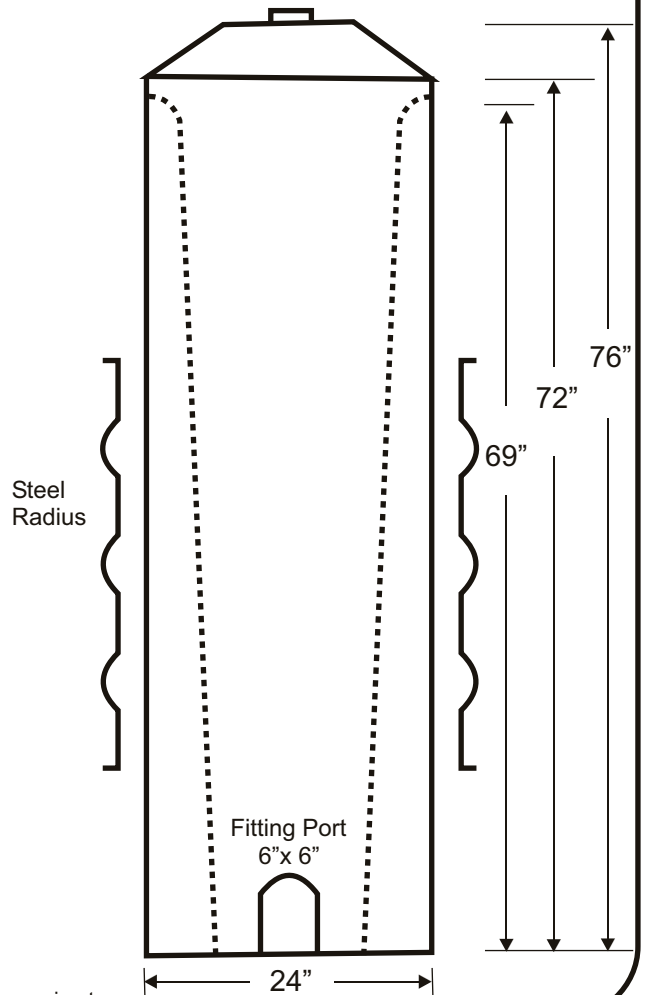

\*Measurements are approximate

- F.D.A. APPROVED FOR POTABLE WATER
- HEAVY DUTY POLYETHYLENE CONSTRUCTION
- SPECIALLY DESIGNED TO FIT THROUGH A STANDARD DOORWAY
- INVERTED RIBS FOR EXTRA STRENGTH
- PORTS AT BOTH ENDS FOR FITTINGS
- STEEL REINFORCING FRAME
- 2 YEAR WARRANTY

**ZEEBEST PLASTICS**

35 Calder Place, St. Albert, AB T8N 5A6  
Ph: 780.447.5222 Fax: 780.455.9448  
www.zeebest.com sales@zeebest.com