

RECTANGULAR TANK R161930

- HEAVY DUTY, ONE-PIECE, SEAMLESS POLYETHYLENE CONSTRUCTION
- EXCELLENT RESISTANCE TO IMPACT AND COLD WEATHER STRESS
- WON'T CRACK, RUST, OR CORRODE
- ULTRAVIOLET INHIBITORS PROVIDE PROTECTION AGAINST DETERIORATION FROM SUNLIGHT
- F.D.A. APPROVED FOR POTABLE WATER
- SUPERIOR CHEMICAL RESISTANCE AND COMPATIBILITY
- 2 YEAR WARRANTY
- DIMENSIONS: 16" x 19" x 30"
- CAPACITY: 32 IMP. GAL. (145 LITRES)

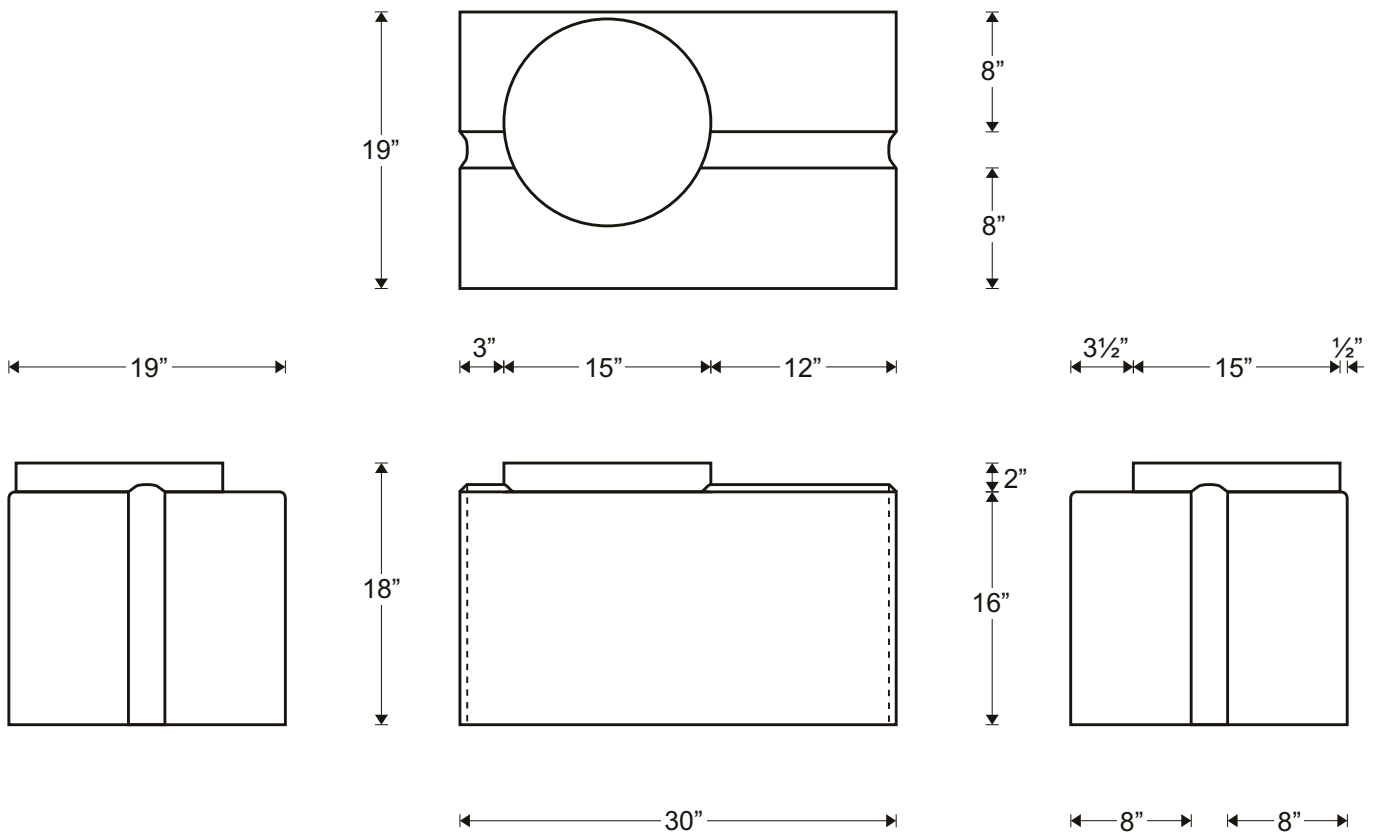

*All Measurements are approximate

ZEEBEST PLASTICS

9704 - 90 Ave., Morinville, AB T8R 1K7
Ph: 780.447.5222 Fax: 780.455.9448
www.zeebest.com sales@zeebest.com