

ZB 100

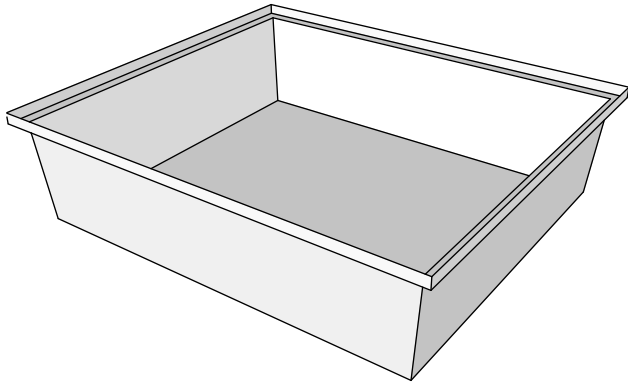

- **HEAVY DUTY, ONE-PIECE, SEAMLESS, POLYETHYLENE CONSTRUCTION**
- **FREE STANDING CONSTRUCTION, NO REINFORCEMENT REQUIRED**
- **EXCELLENT RESISTANCE TO IMPACT AND COLD WEATHER STRESS**
- **WON'T CRACK, RUST OR CORRODE**
- **ULTRAVIOLET INHIBITORS PROVIDE PROTECTION AGAINST DETERIORATION FROM SUNLIGHT**
- **SUPERIOR CHEMICAL RESISTANCE AND COMPATIBILITY**
- **DIMENSIONS: 47" X 54" X 14" H
(42" X 48" INSIDE)**
- **CAPACITY: 100 IMP. GAL.
(450 LITERS)**

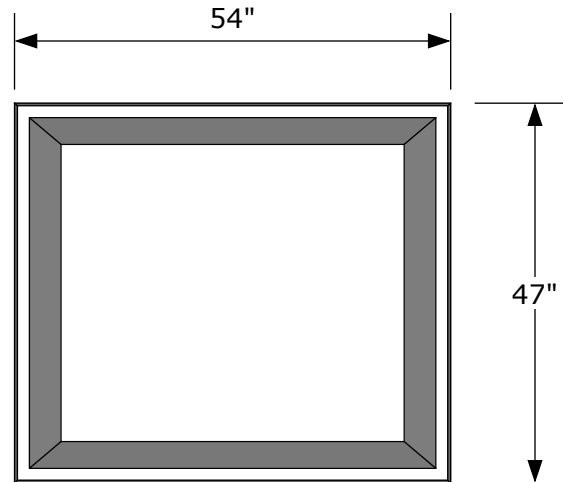
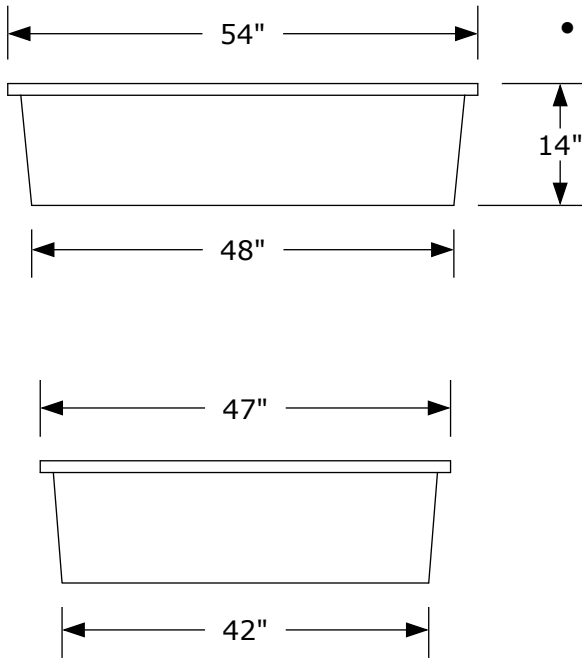

"When Quality Counts"



35 Calder Place, St. Albert, AB T8N 5A6

Tel: 780.447.5222 Fax: 780.455.9448

www.zeebest.com email: sales@zeebest.com