

ZB450 GALLON CONTAINMENT BASIN

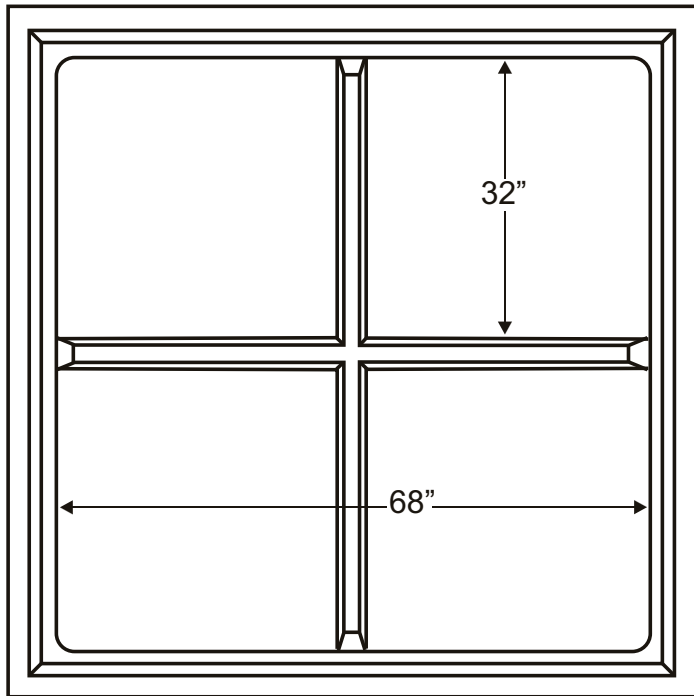

75"

75"

- HEAVY DUTY, ONE-PIECE, SEAMLESS POLYETHYLENE CONSTRUCTION
- FREE STANDING CONSTRUCTION; NO REINFORCEMENT REQUIRED
- EXCELLENT RESISTANCE TO IMPACT AND COLD WEATHER STRESS
- WON'T CRACK, RUST, OR CORRODE
- ULTRAVIOLET INHIBITORS PROVIDE PROTECTION AGAINST DETERIORATION FROM SUNLIGHT
- F.D.A. APPROVED FOR POTABLE WATER
- SUPERIOR CHEMICAL RESISTANCE AND COMPATIBILITY
- IDEAL FOR CONTAINING MOST MATERIALS
- DIMENSIONS: 75" x 75" x 26" H (68" x 68" INSIDE)
- CAPACITY: 450 IMP. GAL. (2045 LITRES)

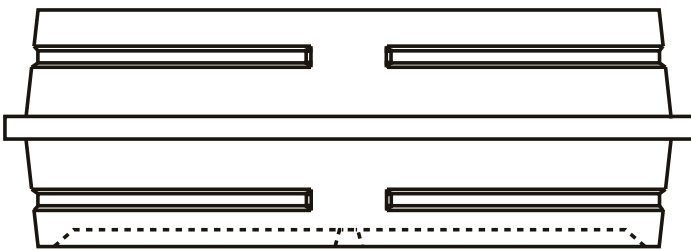

26"

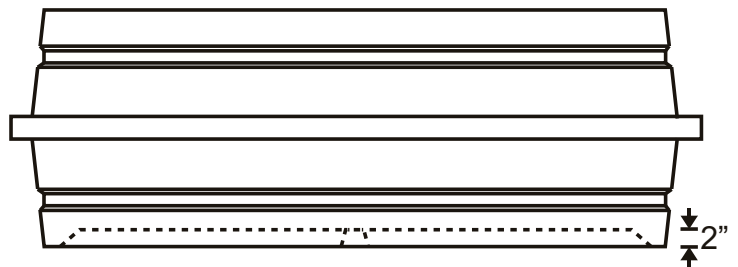

2"

*All Measurements are approximate

ZEEBEST PLASTICS

35 Calder Place, St. Albert, AB T8N 5A6
Ph: 780.447.5222 Fax: 780.455.9448
www.zeebest.com sales@zeebest.com