

HORIZONTAL STORAGE TANK HR1000PR

- HEAVY DUTY, ONE-PIECE, SEAMLESS POLYETHYLENE CONSTRUCTION
- SUPERIOR CHEMICAL RESISTANCE AND COMPATIBILITY
- WON'T CRACK, RUST, OR CORRODE
- EXCELLENT RESISTANCE TO IMPACT AND COLD WEATHER STRESS
- ULTRAVIOLET INHIBITORS PROVIDE PROTECTION AGAINST DETERIORATION FROM SUNLIGHT
- F.D.A. APPROVED FOR POTABLE WATER
- STEEL STANDS AVAILABLE IN STANDARD 4' AND 7' HEIGHTS OR DESIGNED TO YOUR SPECIFICATIONS
- TANK COMES COMPLETE WITH 7" SCREW CAP AND STAINLESS STEEL DRAIN
- DIMENSIONS: 70" DIAMETER x 95" LONG
- CAPACITY: 1000 IMP. GAL. (4500 LITRES)

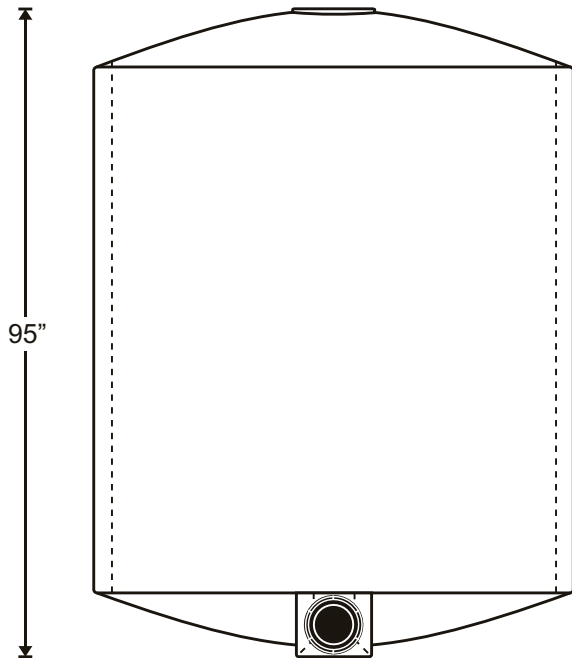

30" 10" 30"

10" 77" 8"

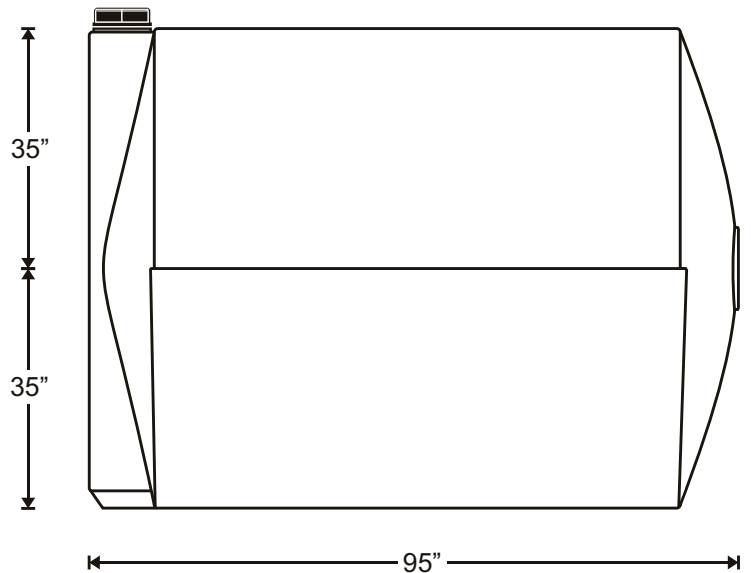
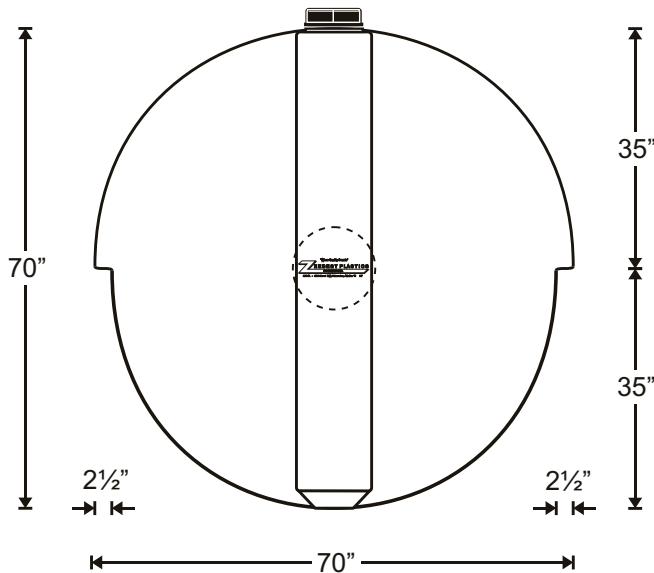

*All Measurements are approximate

ZEEBEST PLASTICS

35 Calder Place, St. Albert, AB T8N 5A6
 Ph: 780.447.5222 Fax: 780.455.9448
 www.zeebest.com sales@zeebest.com