

ZEEBEST SPRAYER TANKS

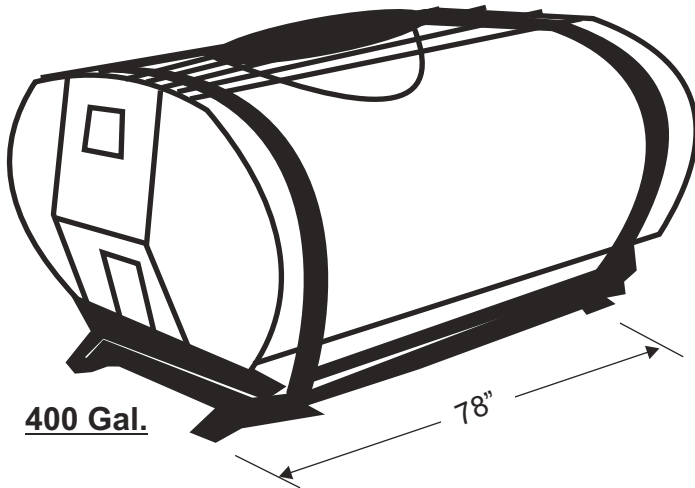
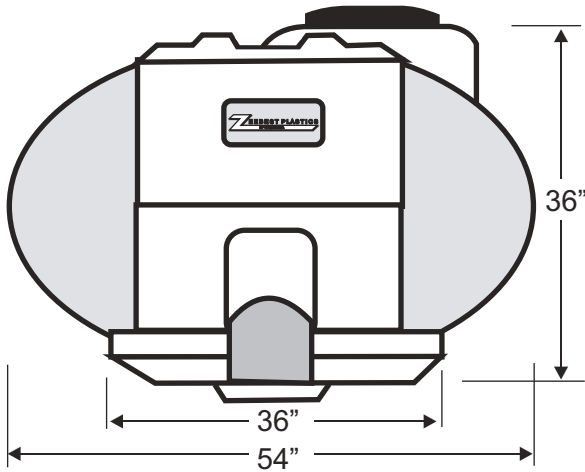

PHOTO: 300 Imp. Gallon Sprayer



- DESIGNED FOR CHEMICAL APPLICATION
- HEAVY DUTY POLYETHYLENE CONSTRUCTION
- ULTRA VIOLET INHIBITORS PROVIDE PROTECTION AGAINST SUNLIGHT
- EXCELLENT RESISTANCE TO VIBRATION & IMPACT
- CORRUGATED RIBS ADD EXTRA STRENGTH
- OFFSET 15" VENTED MANWAY LID
- 2 GAL. SUMP c/w DRAIN KIT ALLOWS FOR COMPLETE DRAINAGE
- CALIBRATED IN IMP. GALLONS
- STEEL BASE & BANDS AVAILABLE
- 2 YEAR WARRANTY

These low profile tanks are specially designed to adapt easily to existing sprayer frames

MODEL	IMP. GAL.	DIMENSIONS
ST300	300	54"W x 59"L x 36"H*
ST400	400	54"W x 78"L x 36"H*

Designed for Cat Challengers



MODEL	IMP. GAL.	DIMENSIONS
LST400	400	29"W x 144"L x 30"H*

*All Measurements are approximate

ZEEBEST PLASTICS

35 Calder Place, St. Albert, AB T8N 5A6
 Ph: 780.447.5222 Fax: 780.455.9448
 www.zeebest.com sales@zeebest.com